

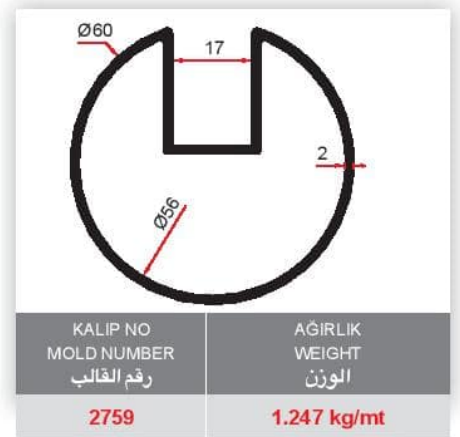

YUVARLAK KÜPEŞTE
ROUND HANDRAIL
الدرابزين الدائري

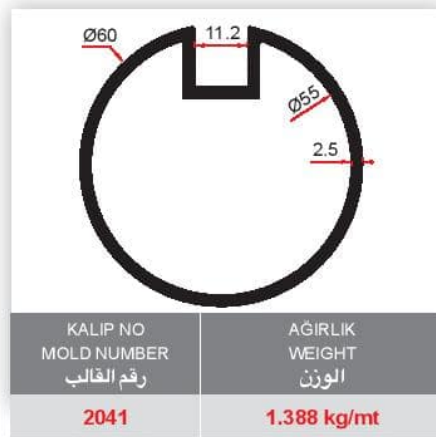

ÜST KÜPEŞTE PROFİLLERİ
UPPER HANDRAIL PROFILES مقاطع درابزين علوية

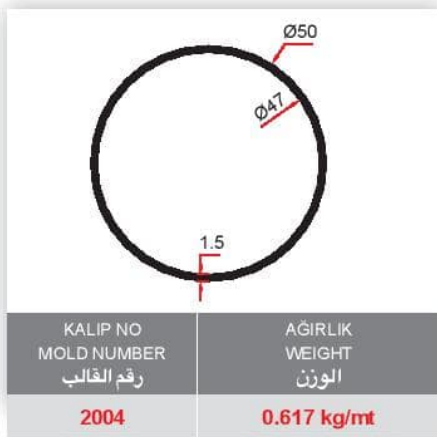
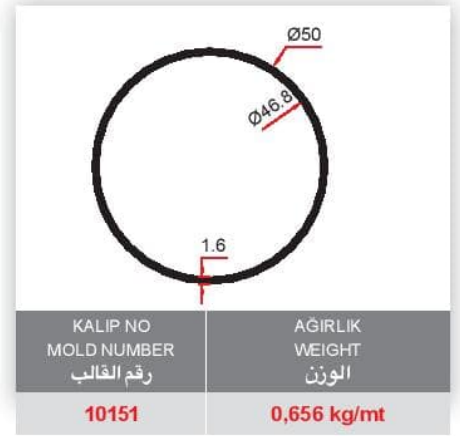
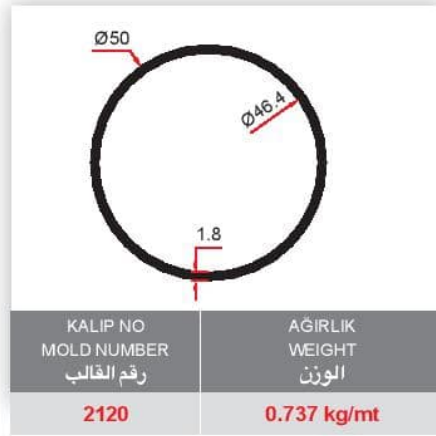
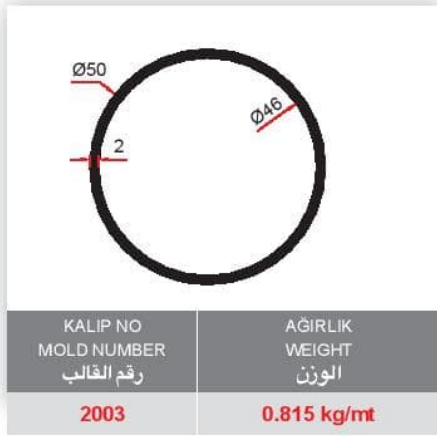
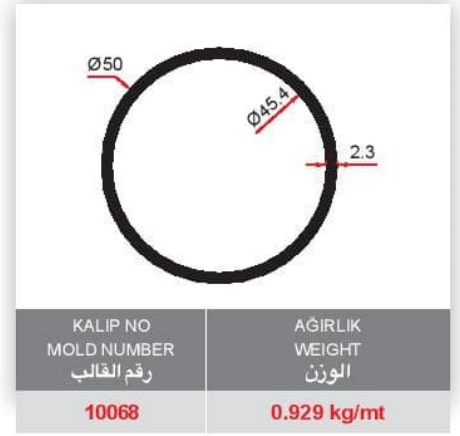
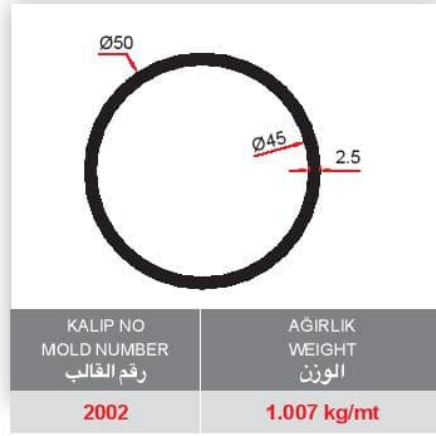
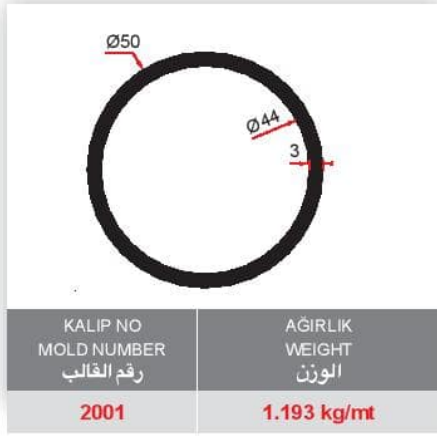

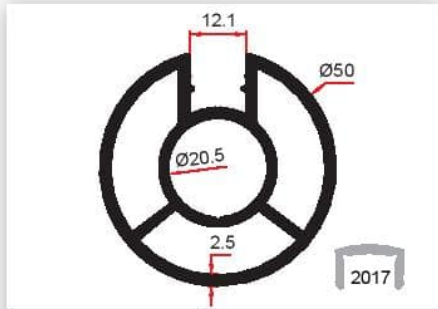

KALIP NO MOLD NUMBER رقم القالب	AĞIRLIK WEIGHT الوزن
2904	1.696 kg/mt

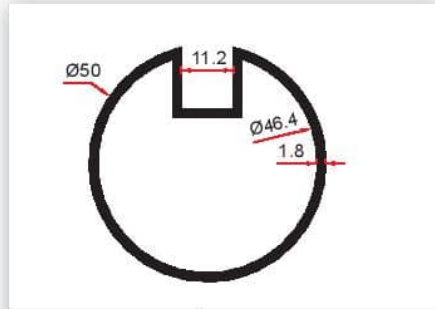

KALIP NO MOLD NUMBER رقم القالب	AĞIRLIK WEIGHT الوزن
2028	0.859 kg/mt

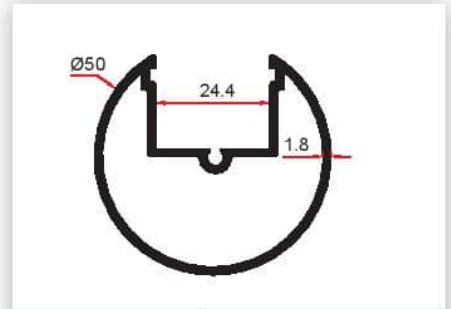

KALIP NO MOLD NUMBER رقم القالب	AĞIRLIK WEIGHT الوزن
2836	0.950 kg/mt

KÜPEŞTE DİKME PROFİLLERİ HANDRAIL BEAM PROFILES

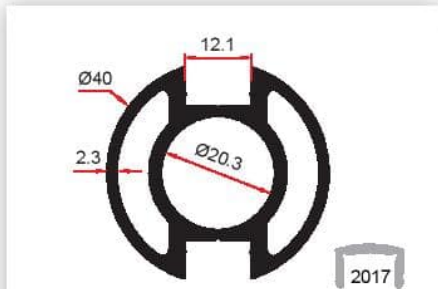

KALIP NO MOLD NUMBER رقم القالب	AĞIRLIK WEIGHT الوزن
2011	1.256 kg/mt

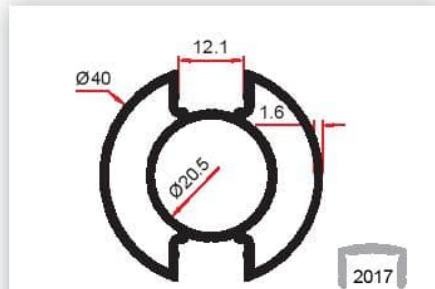

KALIP NO MOLD NUMBER رقم القالب	AĞIRLIK WEIGHT الوزن
2855	0.847 kg/mt

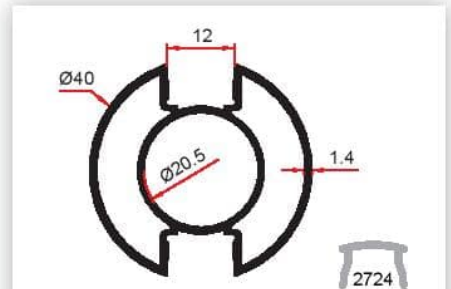

KALIP NO MOLD NUMBER رقم القالب	AĞIRLIK WEIGHT الوزن
2725	0.720 kg/mt

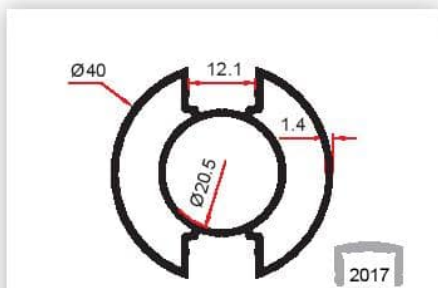

KALIP NO MOLD NUMBER رقم القالب	AĞIRLIK WEIGHT الوزن
2072	0.726 kg/mt

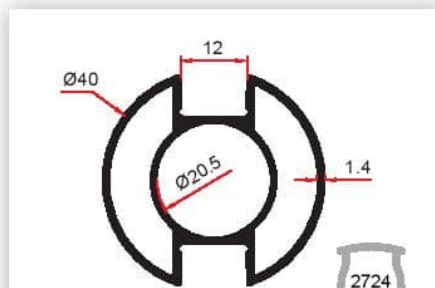

KALIP NO MOLD NUMBER رقم القالب	AĞIRLIK WEIGHT الوزن
2799	0.753 kg/mt

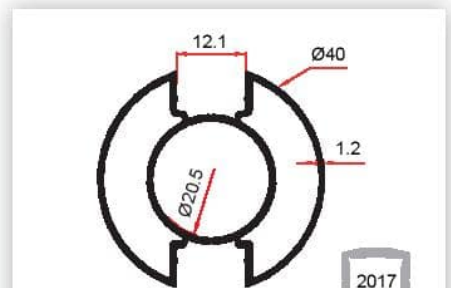

KALIP NO MOLD NUMBER رقم القالب	AĞIRLIK WEIGHT الوزن
2992	0.653 kg/mt

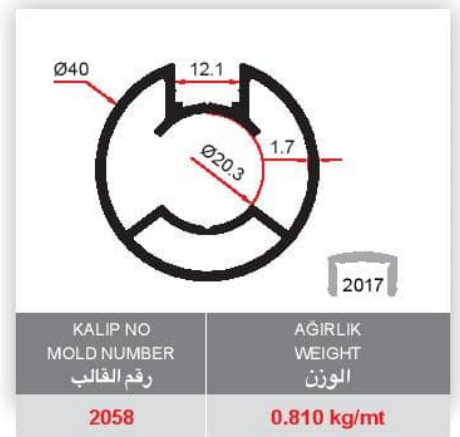
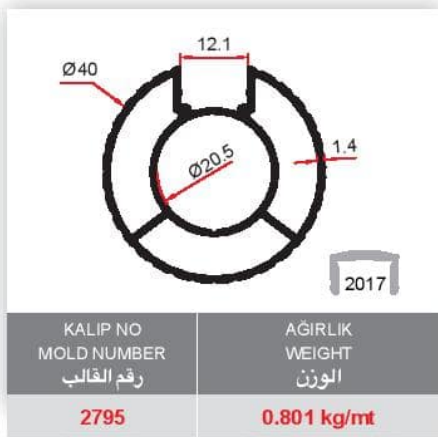
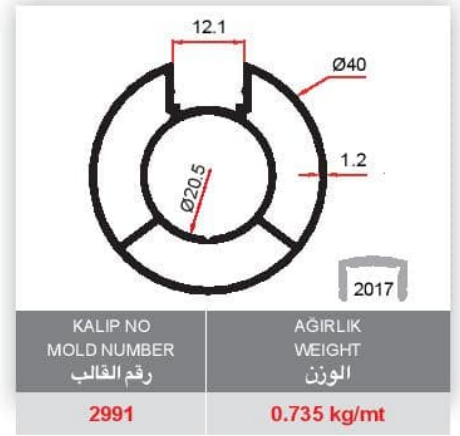
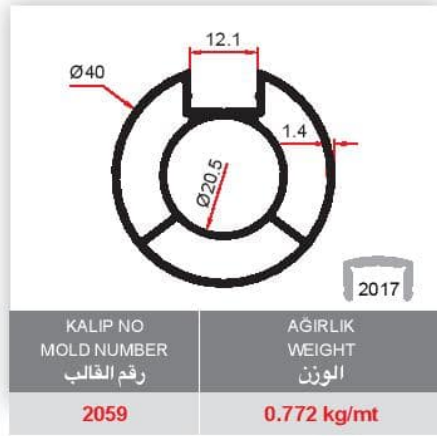
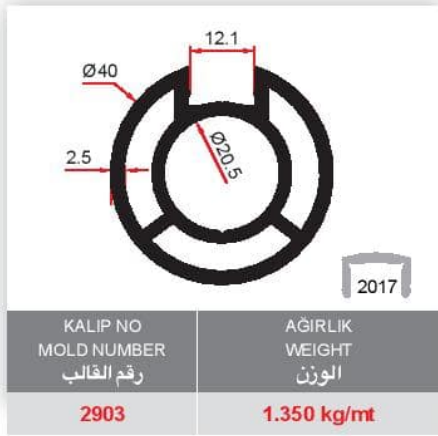
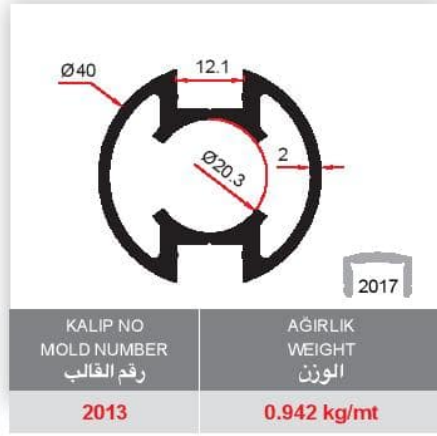
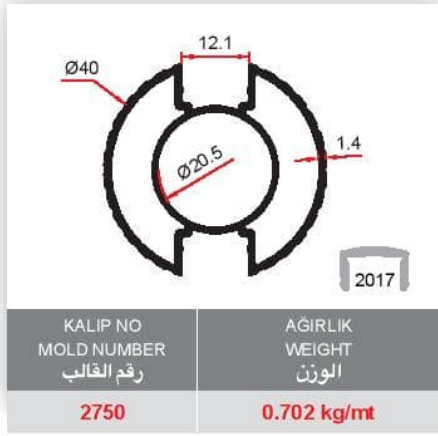

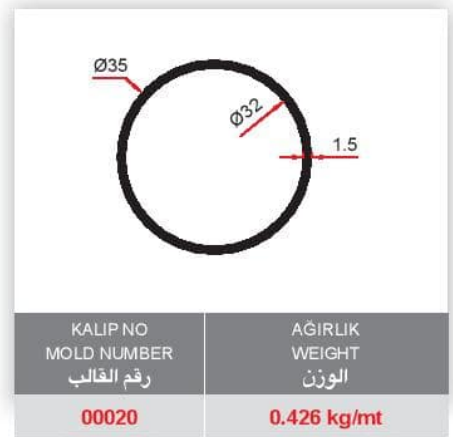
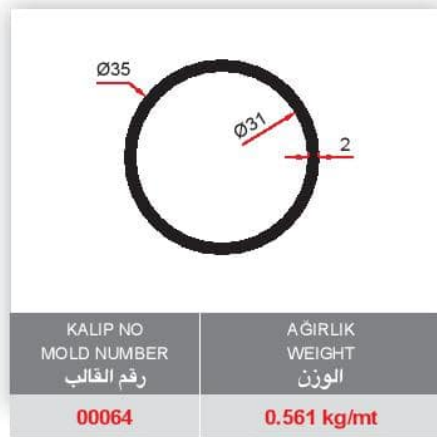
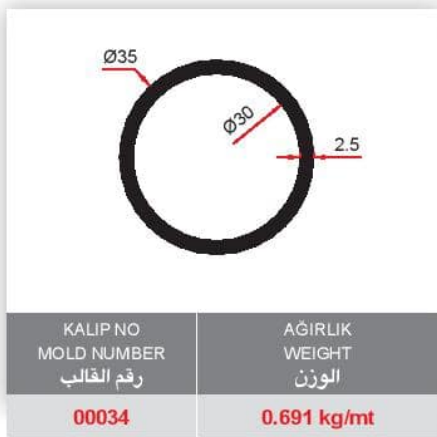
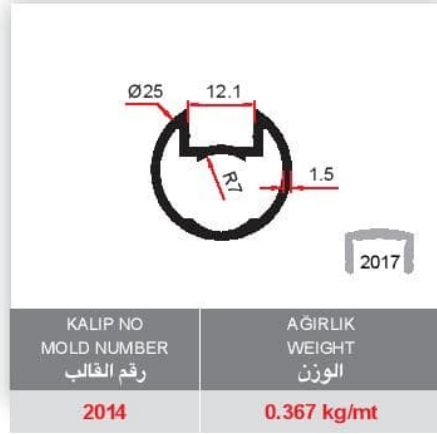
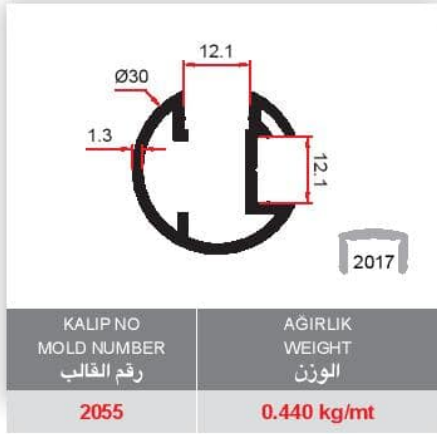
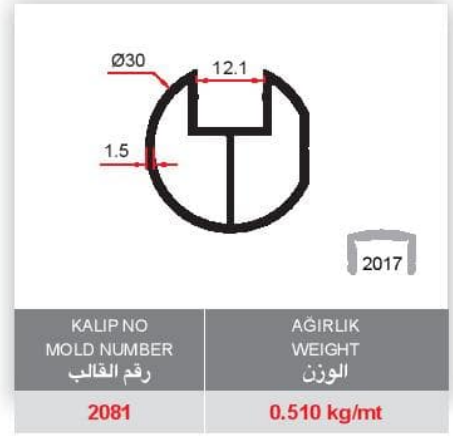
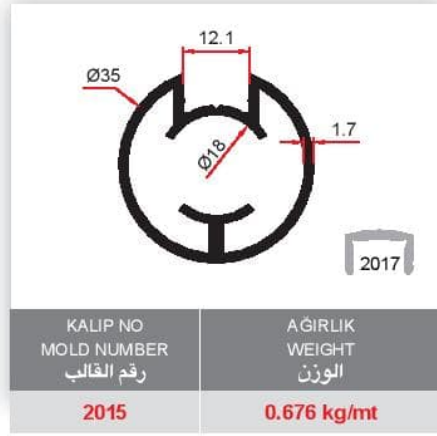

KÜPEŞTE EMNİYET HATLARI
HANDRAIL SAFETY BARS مقاطع امان الدرابزين



KALIP NO MOLD NUMBER رقم القالب	AĞIRLIK WEIGHT الوزن
2786	0.636 kg/mt

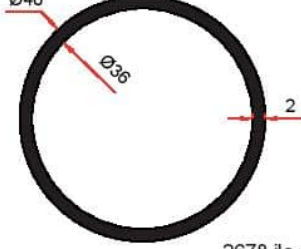

2678 ile çalışır.

KALIP NO MOLD NUMBER رقم القالب	AĞIRLIK WEIGHT الوزن
00024	0.644 kg/mt

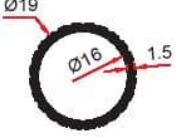

KALIP NO MOLD NUMBER رقم القالب	AĞIRLIK WEIGHT الوزن
2788	0.175 kg/mt



KALIP NO MOLD NUMBER رقم القالب	AĞIRLIK WEIGHT الوزن
00008	0.181 kg/mt

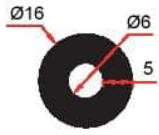

KALIP NO MOLD NUMBER رقم القالب	AĞIRLIK WEIGHT الوزن
10059	0.467 kg/mt

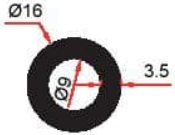

KALIP NO MOLD NUMBER رقم القالب	AĞIRLIK WEIGHT الوزن
00081	0.370 kg/mt



KALIP NO MOLD NUMBER رقم القالب	AĞIRLIK WEIGHT الوزن
00092	0.237 kg/mt

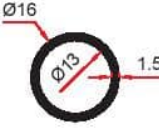

KALIP NO MOLD NUMBER رقم القالب	AĞIRLIK WEIGHT الوزن
00005	0.184 kg/mt



KALIP NO MOLD NUMBER رقم القالب	AĞIRLIK WEIGHT الوزن
10085	0.151 kg/mt

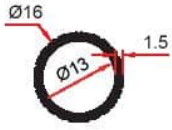

KALIP NO
MOLD NUMBER
رقم القالب

2787

AĞIRLIK
WEIGHT
الوزن

0.175 kg/mt

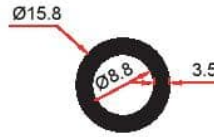

KALIP NO
MOLD NUMBER
رقم القالب

10067

AĞIRLIK
WEIGHT
الوزن

0.366 kg/mt

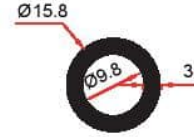

KALIP NO
MOLD NUMBER
رقم القالب

10095

AĞIRLIK
WEIGHT
الوزن

0.326 kg/mt

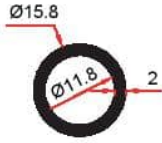

KALIP NO
MOLD NUMBER
رقم القالب

10066

AĞIRLIK
WEIGHT
الوزن

0.235 kg/mt

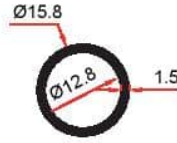

KALIP NO
MOLD NUMBER
رقم القالب

10065

AĞIRLIK
WEIGHT
الوزن

0.184 kg/mt

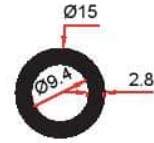

KALIP NO
MOLD NUMBER
رقم القالب

10086

AĞIRLIK
WEIGHT
الوزن

0.290 kg/mt

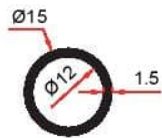

KALIP NO
MOLD NUMBER
رقم القالب

10083

AĞIRLIK
WEIGHT
الوزن

0.170 kg/mt



KALIP NO
MOLD NUMBER
رقم القالب

2724

AĞIRLIK
WEIGHT
الوزن

0.068kg/mt



KALIP NO
MOLD NUMBER
رقم القالب

2017

AĞIRLIK
WEIGHT
الوزن

0.078 kg/mt

PLEKSİ DİKME ve ANGRAJ PROFİLLERİ
حامل بلكسى و مقاطع التثبيت
PLEXY BEAM & ANCHORAGE PROFILES

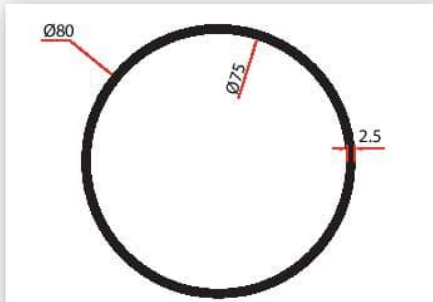

KALIP NO MOLD NUMBER رقم القالب	AĞIRLIK WEIGHT الوزن
10013	1.644 kg/mt

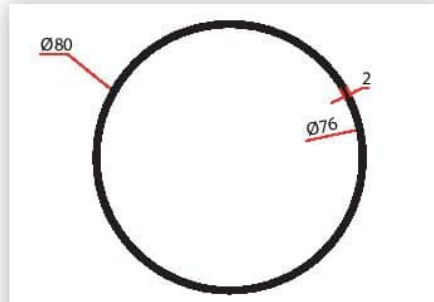

KALIP NO MOLD NUMBER رقم القالب	AĞIRLIK WEIGHT الوزن
10106	1.323 kg/mt

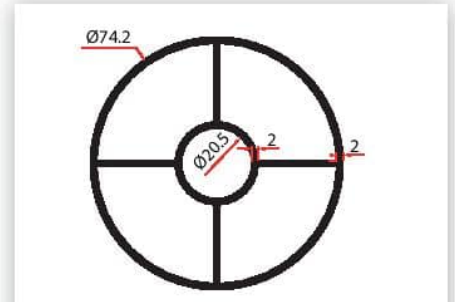

KALIP NO MOLD NUMBER رقم القالب	AĞIRLIK WEIGHT الوزن
10015	2.100 kg/mt

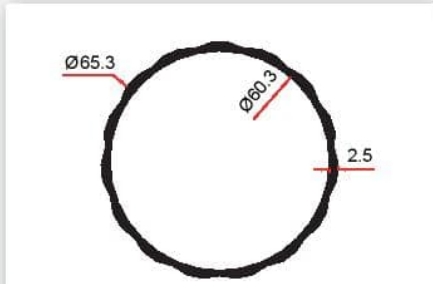

KALIP NO MOLD NUMBER رقم القالب	AĞIRLIK WEIGHT الوزن
2077	1.085 kg/mt

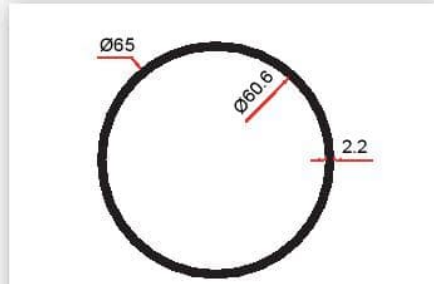

KALIP NO MOLD NUMBER رقم القالب	AĞIRLIK WEIGHT الوزن
10011	1.171 kg/mt

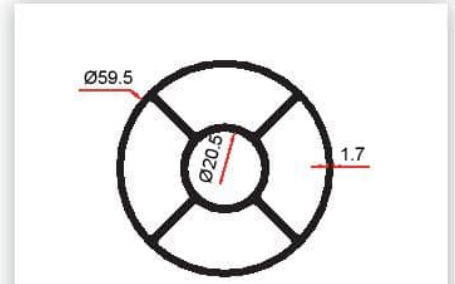

KALIP NO MOLD NUMBER رقم القالب	AĞIRLIK WEIGHT الوزن
2632	1.588 kg/mt

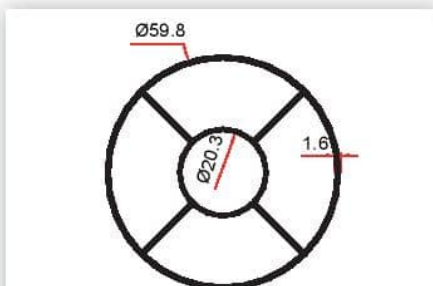

KALIP NO MOLD NUMBER رقم القالب	AĞIRLIK WEIGHT الوزن
2800	1.373 kg/mt

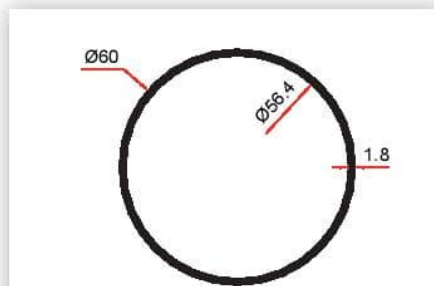

KALIP NO MOLD NUMBER رقم القالب	AĞIRLIK WEIGHT الوزن
10105	0.888 kg/mt

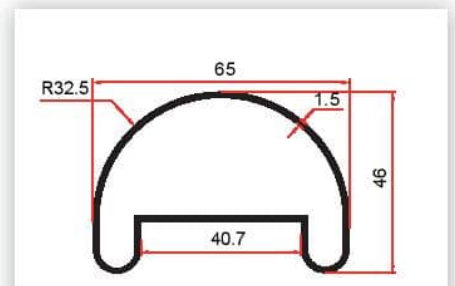

KALIP NO MOLD NUMBER رقم القالب	AĞIRLIK WEIGHT الوزن
2031	0.829 kg/mt

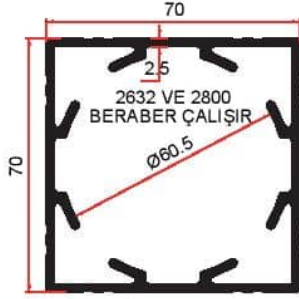

KALIP NO
MOLD NUMBER
رقم القالب

2815

AĞIRLIK
WEIGHT
الوزن

2.422 kg/mt

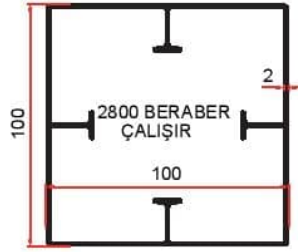

KALIP NO
MOLD NUMBER
رقم القالب

2947

AĞIRLIK
WEIGHT
الوزن

2.700 kg/mt

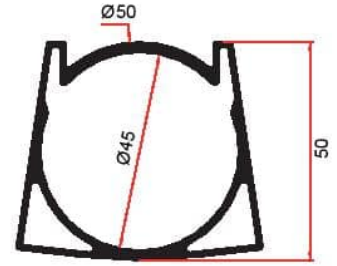

KALIP NO
MOLD NUMBER
رقم القالب

2834

AĞIRLIK
WEIGHT
الوزن

1.298 kg/mt

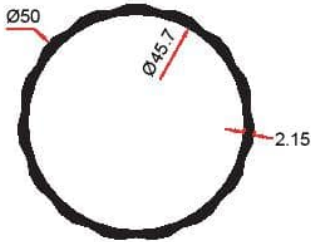

KALIP NO
MOLD NUMBER
رقم القالب

2785

AĞIRLIK
WEIGHT
الوزن

0.733 kg/mt

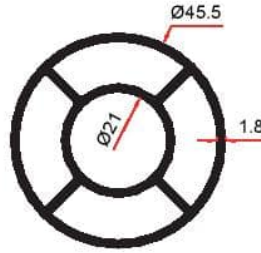

KALIP NO
MOLD NUMBER
رقم القالب

2835

AĞIRLIK
WEIGHT
الوزن

1.183 kg/mt

KALIP NO
MOLD NUMBER
رقم القالب

AĞIRLIK
WEIGHT
الوزن

---- kg/mt

KALIP NO
MOLD NUMBER
رقم القالب

AĞIRLIK
WEIGHT
الوزن

---- kg/mt

KALIP NO
MOLD NUMBER
رقم القالب

AĞIRLIK
WEIGHT
الوزن

---- kg/mt

KALIP NO
MOLD NUMBER
رقم القالب

AĞIRLIK
WEIGHT
الوزن

---- kg/mt